



# ROUGH TERRAIN CRANE

## 75 TONS

LINK-BELT 75IRT

**BOOM LENGTHS:**  
38 TO 142 FT

**JIB LENGTHS:**  
10 TO 58 FT

**JIB OFFSETS:**  
2 - 15 - 30 - 45



# NOTES:

# Technical Data

## Specifications & Capacities

# 75|RT

Telescopic Boom Rough Terrain Crane  
**75 US ton**  
**70 metric ton**



**CAUTION:** This material is supplied for reference use only. Operator must refer to in-cab Crane Rating Manual and Operator's Manual to determine allowable crane lifting capacities and assembly and operating procedures.



PORTLAND OFFICE: 503.283.3111  
SEATTLE OFFICE: 206.784.1054  
[WWW.NESSCAMPBELL.COM](http://WWW.NESSCAMPBELL.COM)

# Table Of Contents

<b>Boom, Attachments, and Upper Structure</b> .....	<b>1</b>
Boom .....	1
Boom .....	1
Boom Wear Pads .....	1
Boom Head .....	1
Boom Elevation .....	1
Auxiliary Lifting Sheave – Optional .....	1
Hook Blocks and Balls – Optional .....	1
Fly – Optional .....	1
Operator’s Cab and Controls .....	1
Swing .....	3
Electrical .....	3
Load Hoist System .....	3
Load Hoist Performance .....	3
Main and Optional Auxiliary Winches .....	3
Hydraulic System .....	3
Counterweight .....	3
<b>Carrier</b> .....	<b>4</b>
General .....	4
Outriggers .....	4
Steering and Axles .....	4
Suspension .....	4
Tires and Wheels .....	4
Brakes .....	4
Electrical .....	4
Engine .....	4
Transmission .....	4
Fuel Tank .....	5
Hydraulic System .....	5
Pump Drive .....	5
Maximum Speed .....	5
Paint .....	5
Additional Equipment Options .....	5
Gradeability .....	5
<b>Axle Loads</b> .....	<b>6</b>
<b>General Dimensions</b> .....	<b>7</b>
<b>General Dimensions</b> .....	<b>8</b>
<b>Working Range Diagram</b> .....	<b>9</b>
<b>Boom Extend Modes</b> .....	<b>10</b>
<b>Main Boom Lift Capacity Charts – Imperial</b> .....	<b>11</b>
14,500lb Counterweight – Fully Extended Outriggers – 360° Rotation .....	11
14,500lb Counterweight On Tires – Stationary – Boom Centered Over The Front Between Tire Tracks .....	12
14,500lb Counterweight On Tires – Boom Centered Over The Front Pick and Carry – Creep .....	13
14,500lb Counterweight On Tires – Stationary – 360° Rotation .....	13



PORTLAND OFFICE: 503.283.3111  
 SEATTLE OFFICE: 206.784.1054  
[WWW.NESSCAMPBELL.COM](http://WWW.NESSCAMPBELL.COM)

<b>Fly Attachment Lift Capacity Charts – Optional</b> .....	<b>14</b>
14,500lb Counterweight – Fully Extended Outriggers – 360° Rotation .....	14
Main Boom + 10 ft Manual Offset Fly (2°, 15°, 30° & 45° Offsets) .....	14
14,500lb Counterweight – Fully Extended Outriggers – 360° Rotation .....	15
35 ft Manual Offset Fly .....	15
58 ft Manual Offset Fly .....	15
<b>Main Boom Lift Capacity Charts – 85% – Metric</b> .....	<b>16</b>
6.6t Counterweight – Fully Extended Outriggers – 360° Rotation .....	16
6.6t Counterweight On Tires – Stationary – Boom Centered Over The Front Between Tire Tracks ...	17
6.6t Counterweight On Tires – Boom Centered Over The Front Pick and Carry – Creep .....	18
6.6t Counterweight On Tires – Stationary – 360° Rotation .....	18
<b>Fly Attachment Lift Capacity Charts – 85% – Optional</b> .....	<b>19</b>
6.6t Counterweight – Fully Extended Outriggers – 360° Rotation .....	19
Main Boom + 3.0m Manual Offset Fly (2°, 15°, 30° & 45° Offsets) .....	19
6.6t Counterweight – Fully Extended Outriggers – 360° Rotation .....	20
10.7m Manual Offset Fly .....	20
17.7m Manual Offset Fly .....	20
<b>Main Boom Lift Capacity Charts – 75% – Metric</b> .....	<b>21</b>
6.6t Counterweight – Fully Extended Outriggers – 360° Rotation .....	21
6.6t Counterweight On Tires – Stationary – Boom Centered Over The Front Between Tire Tracks ...	22
6.6t Counterweight On Tires – Boom Centered Over The Front Pick and Carry – Creep .....	23
6.6t Counterweight On Tires – Stationary – 360° Rotation .....	23
<b>Fly Attachment Lift Capacity Charts – 75% – Optional</b> .....	<b>24</b>
6.6t Counterweight – Fully Extended Outriggers – 360° Rotation .....	24
Main Boom + 3.0m Manual Offset Fly (2°, 15°, 30° & 45° Offsets) .....	24
6.6t Counterweight – Fully Extended Outriggers – 360° Rotation .....	25
10.7m Manual Offset Fly .....	25
17.7m Manual Offset Fly .....	25



PORTLAND OFFICE: 503.283.3111  
 SEATTLE OFFICE: 206.784.1054  
[WWW.NESSCAMPBELL.COM](http://WWW.NESSCAMPBELL.COM)

# Boom, Attachments, and Upper Structure

## ■ Boom

**Design** — Five section, formed construction of extra high tensile steel consisting of one base section and four telescoping sections.

### Boom

- 38–142 ft (11.58–43.28m) five section full power boom
- Two boom extension modes controlled from the operator's cab provides superior capacities by varying the extension of the telescoping sections. EM1 mode extends sections T2, T3, and T4 proportionally to a 116 ft (35.36m) boom length. Next section T1 extends to reach full 142 ft (43.28m) boom length. EM2 mode extends the T1 section to reach a 64 ft (19.51m) boom length. Next sections T2, T3, and T4 extend proportionally to reach the full 142 ft (43.28m) boom length.
- Mechanical boom angle indicator
- Maximum tip height is 151.4 ft (22.4m).

### Boom Wear Pads

- Wear pads with Teflon inserts that self-lubricate the boom sections
- Bottom wear pads are universal for all boom sections
- Top wear pads are universal for all boom sections

### Boom Head

- Five 16.5 in (41.9cm) root diameter nylon sheaves to handle up to ten parts of line
- Easily removable wire rope guards
- Rope dead end lugs on each side of the boom head
- Boom head is designed for quick-reeve of the hook block
- Wind speed indicator
- Aviation obstruction solar marking light and flag — optional

### Boom Elevation

- One double acting hydraulic cylinder with integral holding valve
- Boom elevation:  $-3^{\circ}$  to  $80^{\circ}$

### Auxiliary Lifting Sheave — Optional

- Single 16.5 in (41.9cm) root diameter nylon sheave
- Easily removable wire rope guards
- Does not affect erection of the fly or use of the main head sheaves

## Hook Blocks and Balls — Optional

- 27 ton (25mt) 1 sheave quick-reeve hook block with safety latch
- 60 ton (55mt) 3 sheave quick-reeve hook block with safety latch
- 88 ton (80mt) 5 sheave quick-reeve hook block with safety latch
- 10 ton (9mt) swivel and non-swivel hook balls with safety latch

## Fly — Optional

- 10 ft (3.0m) one piece lattice fly, stowable, offsettable to  $2^{\circ}$ ,  $15^{\circ}$ ,  $30^{\circ}$ , and  $45^{\circ}$ . Maximum tip height is 160 ft (48.8m).
- 35–58 ft (10.7–17.7m) two piece bi-fold lattice fly, stowable, offsettable to  $2^{\circ}$ ,  $15^{\circ}$ ,  $30^{\circ}$ , and  $45^{\circ}$ . Maximum tip height is 208.7 ft (63.6m).
- 10–35–58 ft (3.0–10.7–17.7m) three piece bi-fold lattice fly, stowable, offsettable to  $2^{\circ}$ ,  $15^{\circ}$ ,  $30^{\circ}$ , and  $45^{\circ}$ . Maximum tip height is 208.7 ft (63.6m).

## ■ Operator's Cab and Controls

**Environmental Cab** — Fully enclosed, one person cab of tubular and sheet steel structure with formed plastic interior panels.

Equipped with:

- Tinted and tempered glass windows
- Extra-large fixed front window with time delayed windshield wiper and washer
- Swing up roof window with windshield wiper and washer
- Sliding left side door with large fixed window
- Sliding right side window and pop-out rear window for ventilation
- Six way adjustable, cushioned seat with seat belt and storage compartment
- Diesel fired warm-water heater with ten air ducts for front windshield defroster and cab floor
- Air Conditioning — Integral with cab heating system utilizing the same ventilation outlets and automatic temperature control (ATC)
- Adjustable sun screen
- Dome lights with red nighttime reading LED's
- Cup holder
- Fire extinguisher
- Two position travel swing lock
- AM/FM radio

## Engine Dependent Warm-Water Heater — Optional —

With air ducts for front windshield defroster and cab floor



PORTLAND OFFICE: 503.283.3111  
SEATTLE OFFICE: 206.784.1054

WWW.NESSCAMPBELL.COM

**Steering Column** – Pedestal type with tilt and telescope functions for operator comfort. Column includes the following controls and indicators:

- Horn button
- Turn signal switch
- Driving light switch
- Transmission gear selector
- Transmission Direction Switches
- Travel park brake
- 2/4 wheel drive/range selector
- Hazard flasher

**Armrest Controls** – Two dual axis electronic joystick controllers or optional single axis electronic controllers for:

- Swing
- Boom hoist
- Main (rear) winch
- Auxiliary (front) winch – optional
- Winch high/low speed switch(es)
- Warning horn button
- Swing park brake switch
- Engine throttle lock switch
- Engine set/resume switch
- Cab tilt
- Telescope override

**Outrigger Controls** – Hand held control box with umbilical cord gives the operator the freedom to view operation while setting the outriggers.

#### Foot Controls

- Boom telescope
- Swing brake
- Engine throttle
- Service brake

**Upper Right Console** – Controls and indicators for:

- Engine ignition
- Engine stop
- Function lockout
- Front windshield wiper and washer
- Cab lights and upper frame lights – optional
- Horn
- Dome light with switch
- E–stop switch
- Radio
- DRI on/off selection
- HVAC controller
- 360 swing lock – optional
- Boom floodlights – optional
- Rotating beacon/Strobe light
- Top hatch wiper washer
- Winch(es) disable
- Engine indicator gauge

#### Rear Right Side Panel

- 12V accessory outlet (10amp)
- USB charge port

**Camera Display** – Located on the right A–post with an adjustable mount

- Displays right side of upper
- Displays main and auxiliary winches
- Displays rear view

**Diagnostic Center** – Located on the right rear wall behind the seat.

- Engine diagnostic
- RCL CANBUS diagnostic
- Boom CANBUS diagnostic
- Outrigger CANBUS diagnostic

**Fuse & Relay Panel** – Located on the left rear wall behind the seat.

**Link-Belt Pulse 2.0** – The Link-Belt in-house designed, total crane operating system that utilizes a 10 in touch screen color display with integrated RCL and engine data, advanced diagnostics and systems monitoring, Wi-Fi capable for remote software updates, operator customizable, and a readout and operator interface for the following systems:

- **Rated capacity limiter** – LCD graphic audio – visual warning system integrated into the dash with anti – two block and function limiter. Operating data includes:

- RCL controller USB diagnostic
- Crane configuration
- Boom length and angle
- Boom head height
- Allowed load and % of allowed load
- RCL light bar
- Boom angle
- Radius of load
- Actual load
- Wind speed
- Highlighted unit of measurement on working screen
- Telescope operation displayed in real time
- Steer mode selector
- Outrigger position sensing
- Drum Rotation direction indication
- Third wrap indicator – optional
- Diagnostics
- Operator settable alarms (include):
  - Maximum and minimum boom angles
  - Maximum tip height
  - Maximum boom length
  - Swing left/right positions
  - Operator defined area (imaginary plane)

#### • Cab Instrumentation

- Tachometer
- Engine water temperature
- Fuel level
- Hydraulic oil temperature
- Stop engine
- Check engine
- Wait to start
- Diesel exhaust fluid (DEF) level<sup>(1)</sup>
- Engine air filter high restriction light
- Regeneration light<sup>(1)</sup>
- Regeneration inhibit switch<sup>(1)</sup>
- Regeneration initiate switch<sup>(1)</sup>
- High exhaust temperature light<sup>(1)</sup>
- Regeneration disabled light<sup>(1)</sup>
- Swing park brake light
- Engine speed
- Engine oil pressure
- Battery voltage
- Fuel rate (gal/hr)
- Engine load
- Engine Diagnostics

<sup>(1)</sup> (Tier 4f / Stage IV engine only)

- **Telematics** – Cellular based data logging and monitoring system that provides:

- Location and operational settings
- Routine maintenance
- Crane and engine monitoring
- Diagnostic and fault codes

**Internal RCL Light Bar** – Visually informs the operator when crane is approaching maximum load capacity with a series of green, yellow, and red lights.

**Integrated Third Wrap Indicator – Optional** – Link-Belt Pulse 2.0 color display visually and audibly warns the operator when the wire rope is on the first/bottom layer and when the wire rope is down to the last three wraps.

**Integrated Third Wrap Function Kickout – Optional** – Link-Belt Pulse 2.0 color display visually and audibly warns the operator when the wire rope is on the first/bottom layer and provides a function kickout when the wire rope is down to the last three wraps.

**External RCL Light Bar – Optional** – Visually informs the ground crew when crane is approaching maximum load capacity with a series of green, yellow, and red lights.

## ■ Swing

**Motor/Planetary** – Bi-directional hydraulic swing motor mounted to a planetary reducer for 360° continuous smooth swing at 1.9 rpm

**Swing Park Brake** – 360°, electric over hydraulic, (spring applied/hydraulic released) multi-disc brake mounted on

the speed reducer. Operated by a switch in the operator's cab.

**Swing Brake** – 360°, foot operated, speed reducing system with disc brake hold feature

**Swing Lock** – Two-position swing lock (boom over front or rear) operated from the operator's cab

**360° Positive Swing Lock – Optional** – Meets New York City requirement

## ■ Electrical

**Swing Alarm** – Audio warning device signals when the upper is swinging.

### Lights

- Two LED working lights on front of the cab
- Two amber strobe lights at rear of the upper frame
- One LED working light on top of cab – optional
- LED Boom floodlight – Single – optional
- LED Boom floodlight – Dual – optional
- LED Boom floodlight – High intensity remote controlled – optional
- LED Frame work lights – right front, left rear, and work platform – optional

## ■ Load Hoist System

### Load Hoist Performance

Main (Rear) and Auxiliary (Front) Winches – 3/4 in (19mm) Rope										
Layer	Maximum Line Pull		Normal Line Speed		High Line Speed		Layer		Total	
	lb	kN	ft/min	m/min	ft/min	m/min	ft	m	ft	m
1	18,603	82.8	168	51.2	359	109.4	114	34.7	114	34.7
2	17,103	76.08	183	55.8	391	119.2	124	37.8	238	72.5
3	15,827	70.4	198	60.4	422	128.6	134	40.8	372	113.4
4	14,728	65.51	212	64.6	454	138.4	144	43.9	516	157.3
5	13,772	61.26	227	69.2	485	147.8	154	46.9	670	204.2

Wire Rope Application		Diameter		Type	Maximum Permissible Load	
		in	mm		lb	kg
Main (Rear) Winch	Standard	3/4	19	37x7 rotation resistant – right lang lay (Type KC)	16,000	7 257.5
	Optional	3/4	19	35x7 rotation resistant – right lang lay (Type CC)	17,160	7 783.6
Auxiliary (Front) Winch	Standard	3/4	19	37x7 rotation resistant – right lang lay (Type KC)	16,000	7 257.5
	Optional	3/4	19	35x7 rotation resistant – right lang lay (Type CC)	17,160	7 783.6

### Main and Optional Auxiliary Winches

- Axial piston, full and half displacement (2-speed) motors driven through planetary reduction unit for positive control under all load conditions
- Grooved lagging
- Power up/down mode of operation
- Drum rotation indicator(s)
- Drum diameter: 16 in (40.6cm)
- Rope length:
  - Front: 500 ft (152.4m)
  - Rear: 600 ft (182.9m)
- Maximum rope storage: 670 ft (204.2m)
- Terminator style socket and wedge
- Encoders for reading rope payout
- Hoist drum cable followers – optional

## ■ Hydraulic System

**Counterbalance Valves** – All hoist motors, boom extend cylinders, and boom hoist cylinders are equipped with counterbalance valves to control load lowering. This prevents accidental load drop when hydraulic power is suddenly reduced.

## ■ Counterweight

Total of 14,500 lb (6.6t) counterweight pinned to the upper with capacities for:

- 0 lb (0t) counterweight\*
- 14,500 lb (6.6t) counterweight

**Hydraulic counterweight removal** – optional – activated by a hand-held controller with enough cable to access the pins on each side of the counterweights.

\* Travel speed limited to 5 mph.



PORTLAND OFFICE: 503.283.3111  
SEATTLE OFFICE: 206.784.1054

WWW.NESSCAMPBELL.COM



## Carrier

### General

- 10 ft 7 in (3.22m) wide
- 14 ft 7 in (4.45m) wheelbase (centerline of first axle to centerline of second axle)

**Frame** — Box—type, torsion resistant, welded construction made of high tensile steel. Equipped with front and rear towing and tie—down lugs, tow connections, and access ladders.

### Outriggers

**Boxes** — Two double box, front and rear welded to carrier frame

**Beams and Jacks** — Four single stage beams that are hydraulically controlled from the operator's cab with integral check valves.

**V—CALC** — Variable confined area lifting capabilities that are incorporated directly into the Pulse 2.0 display allowing multiple outrigger configurations of fully extended, intermediate, and fully retracted selectable in pairs, with live on screen working radii, utilizing 360° charts, and swing arrest.

**Pontoons** — Four lightweight, quick release, 24 in (61cm), steel pontoons with contact area of 452 in<sup>2</sup> (2 916cm<sup>2</sup>) can be stored for road travel in storage racks on the carrier.

**Main Jack Reaction** — 93,000 lb (42 186kg) force and 206 psi (1 420kPa) ground bearing pressure.

### Steering and Axles

**Steering** — Four independent modes consisting of two wheel front, two wheel rear, four wheel, and crab. Each mode is controlled from the steering wheel and is selected by a switch in the operator's cab.

**Drive** — Two modes: 4 x 2 and 4 x 4 for off highway travel

**Axle 1** — Steered, non—driven for 4 x 2 and steered, driven for 4 x 4

**Axle 2** — Steered, driven

### Suspension

**Front** — Rigid mount to the carrier frame

**Rear** — The rear axle is suspended on the oscillation cylinders with motion of the axle controlled by a four bar linkage system. The oscillation cylinders lockout when the upper structure rotates 2.5° past centerline.

- Hydro—gas rear suspension — optional

### Tires and Wheels

**Front and Rear** — Four (single) 26.5 x 25—32 ply rating, earthmover type tires on steel disc wheels

- Spare tires and wheels — optional

### Brakes

**Service** — Full hydraulic, dual circuit, disc type brakes on all wheel ends

**Parking/Emergency** — Spring applied type, acting on front axle

### Electrical

Two batteries provide 24 volt starting and operation

#### Lights

- All lights are LED.
- Front lighting includes two main headlights, outrigger lights, and two parking/directional indicators.
- Side lighting includes two parking/directional indicators per side.
- Rear lighting includes two parking/directional indicators, two parking/brake lights, and two reversing lights.
- Other equipment includes hazard/warning system, cab light, instrument panel light, and signal horn.

### Engine

Specification	Cummins QSB	
Numbers of Cylinders	6	6
Cycle	4	4
Emissions Compliance Level:	Tier 4f/Stage IV <sup>(1)</sup>	Tier 3/Stage IIIA <sup>(2)</sup>
Bore and Stroke: inch (mm)	4.21 x 4.88 (107 x 124)	4.21 x 4.88 (107 x 124)
Piston Displacement: in <sup>3</sup> (L)	408 (6.7)	408 (6.7)
Max. Brake Horsepower: hp (kW)	270 (201) @ 2,000 rpm	270 (201) @ 2,000 rpm
	260 (194) @ 2,200 rpm	260 (194) @ 2,200 rpm
Peak Torque: ft lb (Nm)	730 (990) @ 1,500 rpm	730 (990) @ 1,500 rpm
Electric/starting systems: volts	24/24	24/24
Alternator: amps	140	140
Crankcase Capacity: qt (L)	15 (14.2)	15 (14.2)
<ul style="list-style-type: none"> <li>• Water/fuel separator w/ heater and water in fuel (WIF) sensor</li> <li>• 120—volt block heater — Tier 4f / Stage IV</li> <li>• 220—volt block heater — Tier 3 / Stage IIIA</li> <li>• Grid heater — 112 amp</li> <li>• Mechanically driven, variable speed, engine controlled, viscous fan clutch</li> <li>• <sup>(1)</sup> Can only be sold and/or operated where Tier 4f and Stage IV off—highway emission standards are accepted.</li> <li>• <sup>(2)</sup> Can only be sold and/or operated where Tier 3 and Stage IIIA off—highway emission standards are accepted.</li> </ul>		

### Transmission

**Powershift** — Three speed with high/low range for 6 forward and 6 reverse gears. Front axle disconnect for two or four wheel drive. Front axle disconnects in high range.



PORTLAND OFFICE: 503.283.3111  
SEATTLE OFFICE: 206.784.1054

WWW.NESSCAMPBELL.COM

## ■ Fuel Tank

One 75 gallon (283.9L) capacity tank

### Diesel Exhaust Fluid (DEF) tank<sup>(1)</sup>

- One 5 gal (18.9L) capacity tank

<sup>(1)</sup> (Tier 4f / Stage IV engine only)

## ■ Hydraulic System

All functions are hydraulically powered allowing positive precise control with independent or simultaneous operation of all functions.

### Main Pumps

- One variable displacement, load sense, piston pump with anti–stall for the front/rear winches, boom hoist, and telescope circuits.
- One two section fixed displacement gear pump for the power steering/swing and for the service brakes/outriggers/oscillation/counterweights.
- One single section gear pump for the hydraulic oil cooler fan drive.
- Combined pump capacity of 127 gpm (480.7Lpm)

**Hydraulic Reservoir** – 173 gal (654.9L) capacity equipped with sight level gauge. Diffusers built in for deaeration.

**Filtration** – One 5 micron, full flow line filter in the control circuit. All oil is filtered prior to return to reservoir. Accessible for easy filter replacement.

**Hydraulic Oil Coolers** – One carrier mounted cooler removes heat from the hydraulic oil. Remote mounted on right side of the carrier.

## ■ Pump Drive

All pumps are mounted on the transmission and mechanically driven by the diesel engine.

## ■ Maximum Speed

20.8 mph (33.47 km/h)

## ■ Gradeability

Counterweight	Ascending		Descending		Side	
	Degrees	% Grade	Degrees	% Grade	Degrees	% Grade
0	16.0	29%	6.0	11%		
14,500 lbs (6.6t)	14.0	25%	14.0	25%	5.0	9%

## ■ Paint

Entire machine is pre-painted and oven baked with Highsolid Paint (2 part epoxy/polyester) and/or (2 part epoxy primer/2 part polyurethane top coat). Standard Link-Belt Red, Link-Belt Gray, and Gloss Black colors apply.

## ■ Additional Equipment Options

- Spark arrestor – optional
- Engine air intake shutoff valve – optional

## Axle Loads

Base crane with full tank of fuel	Gross Vehicle Weight (1)		Upper Facing Front				Upper Facing Rear			
	lb	kg	Front Axles		Rear Axles		Front Axles		Rear Axles	
			lb	kg	lb	kg	lb	kg	lb	kg
Tier 4f / Stage IV	92,996	42 182	44,682	20 268	48,313	21 915	39,354	17 851	53,642	24 332
Tier 3 / Stage IIIA	92,427	41 924	44,527	20 197	47,901	21 727	39,198	17 780	53,229	24 144
Pintle hook, front	13	6	17	8	-4	-2	17	8	-4	-2
Pintle hook, rear	13	6	-5	-2	18	8	-5	-2	18	8
Hydro-gas suspension	61	28	22	10	39	18	22	10	39	18
Battery w/ AGM (Use with cold weather package)	30	14	-11	-5	41	19	-11	-5	41	19
Battery w/ Cap-AGM (Use with Arctic package)	43	20	-16	-7	59	27	-16	-7	59	27
Operator in cab	250	113	134	61	116	53	103	47	147	67
Hoist drum follower – main	68	31	-28	13	96	44	93	42	-25	11
Auxiliary winch with 500 ft (152.4m) wire rope	721	327	-101	-46	822	373	785	785	-64	-29
Hoist drum follower – auxiliary	69	31	-17	-8	86	39	83	38	-14	-6
Substitute 500 ft (152.4m) wire rope with 600 ft (182.9m) – auxiliary	121	55	-15	-7	136	62	130	59	-9	-4
Remove 600 ft (182.9m) wire rope from rear (main) winch	-744	-337	216	98	-960	-435	-922	-418	178	81
Remove 500 ft (152.4m) wire rope from front (auxiliary) winch	-623	-283	88	40	-711	-323	-679	-308	56	25
Remove 14,500 lbs (6.6t) counterweight	-14,520	-6 586	5,235	2 375	-19,755	-8 961	-19,009	-8 622	4,489	2 036
Counterweight Removal	187	85	-58	-26	245	111	235	107	-48	-22
Emergency steering	220	100	39	18	181	82	170	77	50	23
360° mechanical swing lock	152	69	64	29	88	40	80	36	72	33
Floodlight to front of boom base section	37	17	93	42	-56	-25	-58	-26	95	43
Fly mounting brackets to boom base section for fly options	232	105	323	147	-91	-41	-103	-47	335	152
10 ft (3.0m) offsettable fly – stowed	1,062	482	2,458	1 115	-1,396	-633	-1,450	-658	2,512	1 139
10–35 ft (3.0–10.67m) offsettable fly – stowed	2,044	927	3,406	1 545	-1,362	-618	-1,467	-665	3,511	1 593
10–35–58 ft (3.0–10.67–17.68m) offsettable fly – stowed	2,745	1 245	4,073	1 847	-1,328	-602	-1,469	-666	4,214	1 911
35 ft (10.67m) offsettable fly – stowed	1,580	717	2,501	1 134	-921	-418	-1,002	-454	2,582	1 171
35–58 ft (10.67–17.68m) offsettable fly – stowed	2,281	1 035	3,168	1 437	-887	-402	-1,004	-455	3,285	1 490
Auxiliary lifting sheave	110	50	297	135	-187	-85	-193	-88	303	137
60 ton (54.4mt) 3–sheave hook block Flexi–weight at bumper	1,401	636	2,065	937	-664	-301	-737	-334	2,138	970
88 ton (79.8mt) 5–sheave hook block Flexi–weight at bumper	1,613	732	2,378	1 079	-765	-347	-848	-385	2,461	1 116
27 ton (24.5mt) 1–sheave hook block Flexi–weight at bumper	843	382	1,243	564	-400	-181	-443	-201	1,286	583
10 ton (9.1mt) hook ball at bumper	580	263	855	388	-275	-125	-305	-138	885	401
60 ton (54.4mt) 3–sheave hook block Flexi–weight at boom head	1,401	636	3,643	1 652	-2,242	-1 017	-2,314	-1 050	3,715	1 685
88 ton (79.8mt) 5–sheave hook block Flexi–weight at boom head	1,613	732	4,360	1 978	-2,747	-1 246	-2,830	-1 284	4,443	2 015
10 ton (9.1mt) hook ball at boom head	580	263	1,508	684	-928	-421	-958	435	1,538	698

Tire	Maximum Allowable Axle Load @ 20 mph (32.2km/h)
26.5 x 25 (32–PR)	55,000 lb (24 948kg)

(1) Adjust gross vehicle weight and axle loading according to component weight.  
Note: All weights are ±3%.

(1) Adjust gross vehicle weight and axle loading according to component weight.  
Note: All weights are ±3%.



PORTLAND OFFICE: 503.283.3111  
SEATTLE OFFICE: 206.784.1054  
[WWW.NESSCAMPBELL.COM](http://WWW.NESSCAMPBELL.COM)

# General Dimensions

## Tier 4f / Stage IV

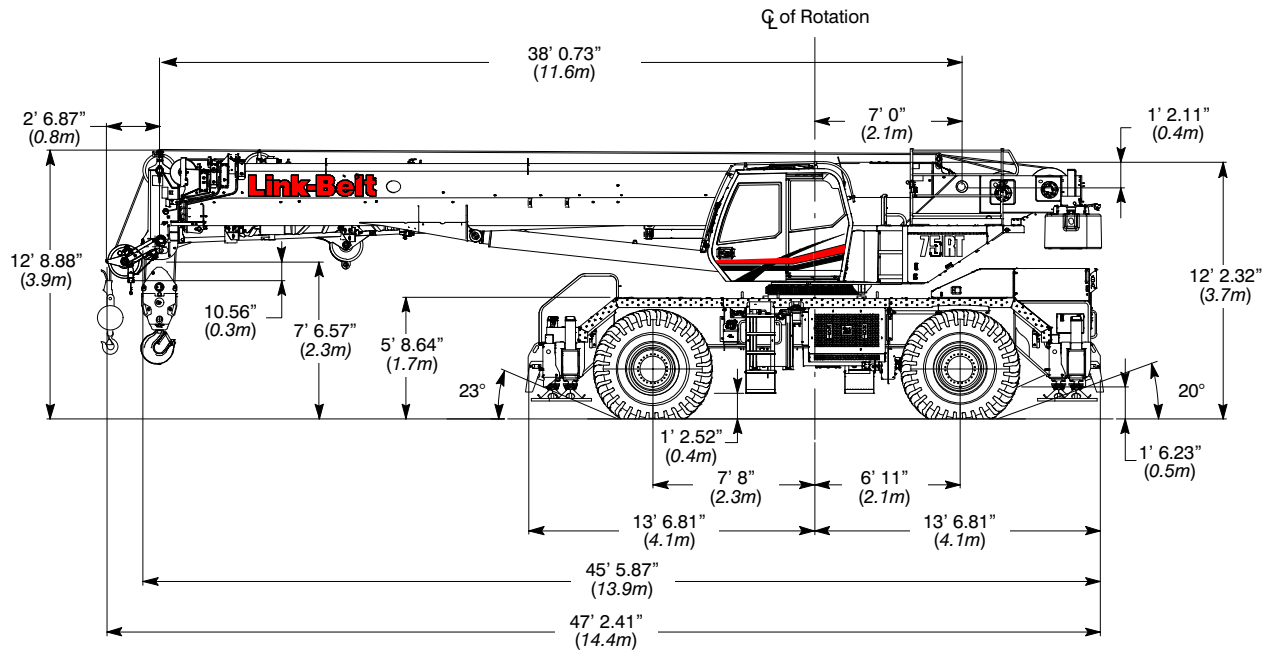

Turning Radius – Front Wheel (4x2) Steering		
	English	Metric
Wall to wall over carrier	43' 2"	13.2m
Wall to wall over boom attachment	53' 3"	16.2m
Curb to curb	41' 6"	12.6m
Centerline of tire	40' 0"	12.2m

Turning Radius – All Wheel (4x4) Steering		
	English	Metric
Wall to wall over carrier	26' 6"	8.1m
Wall to wall over boom attachment	38' 0"	11.6m
Curb to curb	24' 10"	7.6m
Centerline of tire	23' 6"	7.2m

Tail Swing		
	English	Metric
With counterweight	13' 7.98"	4.17m
Without counterweight	13' 0.73"	4.0m

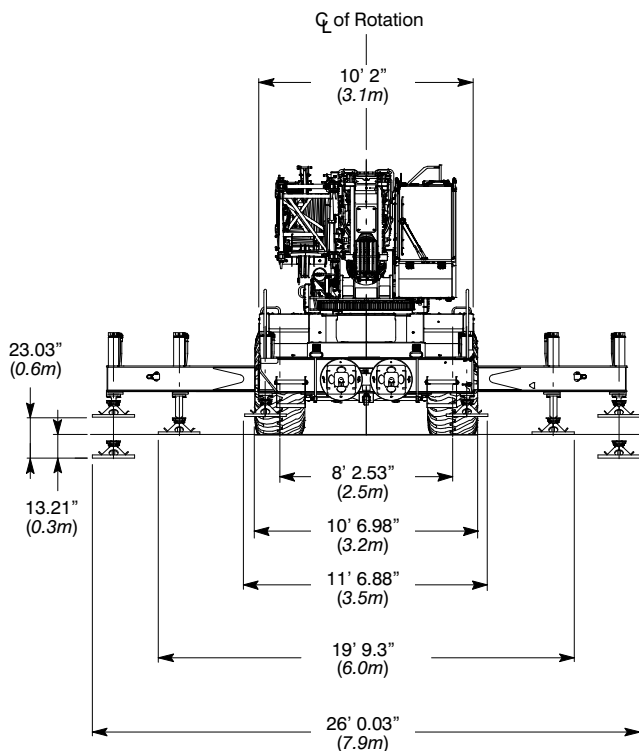

Not To Scale



PORTLAND OFFICE: 503.283.3111  
 SEATTLE OFFICE: 206.784.1054  
[WWW.NESSCAMPBELL.COM](http://WWW.NESSCAMPBELL.COM)

# Working Range Diagram

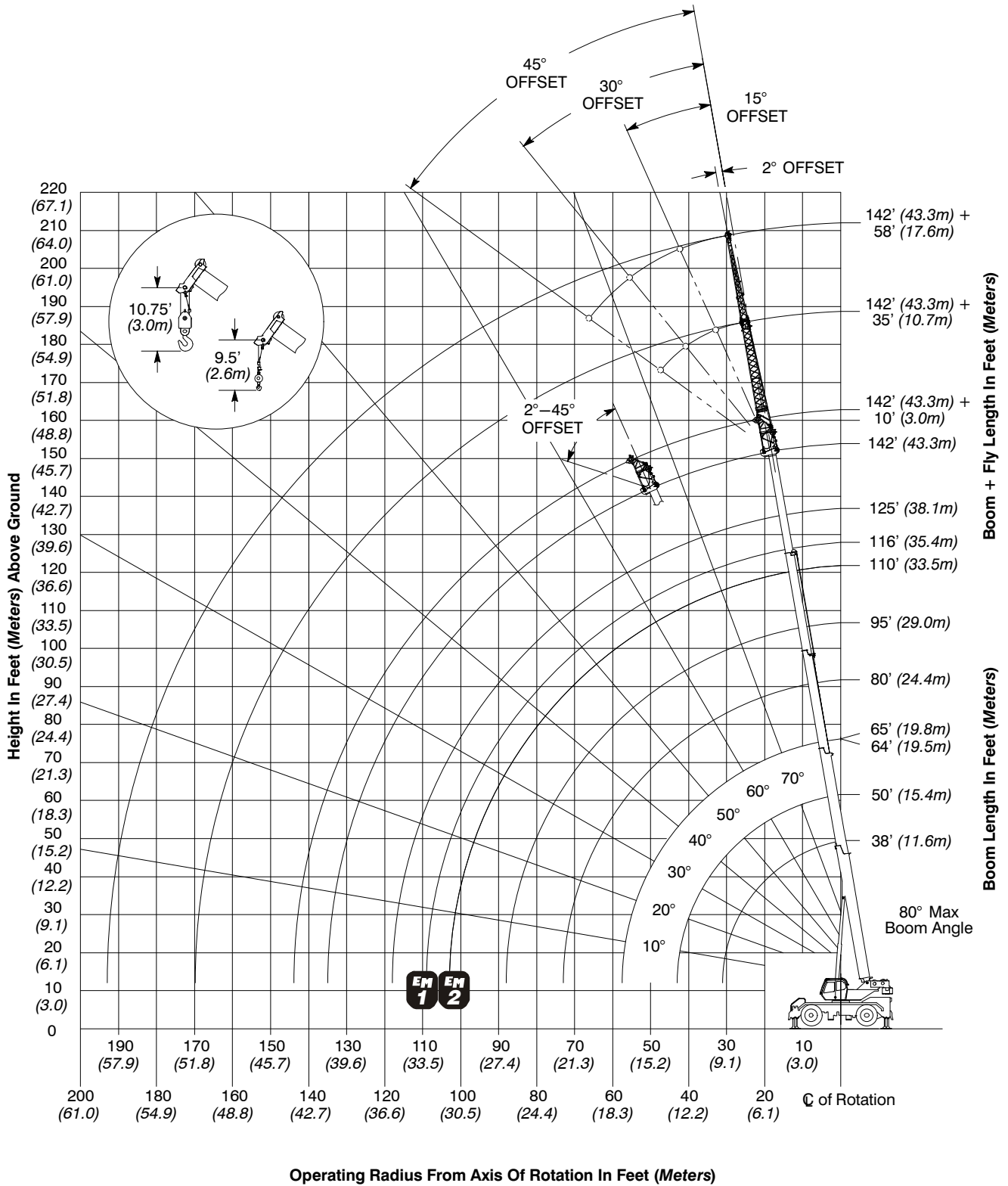

PORTLAND OFFICE: 503.283.3111  
 SEATTLE OFFICE: 206.784.1054  
[WWW.NESSCAMPBELL.COM](http://WWW.NESSCAMPBELL.COM)

# Boom Extend Modes

	Boom Length		Telescope Length			
	ft	m	T4	T3	T2	T1
*	38	11.58				
	50	15.24	15%	15%	15%	
*	65	19.81	35%	35%	35%	
	80	24.38	54%	54%	54%	
**	90	27.43	67%	67%	67%	
	95	28.96	73%	73%	73%	
*	116	35.36	100%	100%	100%	
	125	38.10	100%	100%	100%	35%
*	142	43.28	100%	100%	100%	100%

EM  
1

	Boom Length		Telescope Length			
	ft	m	T4	T3	T2	T1
*	38	11.58				
	50	15.24				46%
*	64	19.51				100%
	80	24.38	21%	21%	21%	100%
**	85	25.91	27%	27%	27%	100%
	95	28.96	40%	40%	40%	100%
*	110	33.53	59%	59%	59%	100%
	125	38.10	78%	78%	78%	100%
*	142	43.28	100%	100%	100%	100%

EM  
2

\* Denotes boom lengths charted with main boom and 10', 35' or 58' fly capacities.

\*\* Denotes boom lengths charted with 35' or 58' fly capacities only.



PORTLAND OFFICE: 503.283.3111  
 SEATTLE OFFICE: 206.784.1054  
[WWW.NESSCAMPBELL.COM](http://WWW.NESSCAMPBELL.COM)

# Main Boom Lift Capacity Charts – Imperial

14,500lb Counterweight – Fully Extended Outriggers – 360° Rotation (All Capacities Are Listed In Pounds)									
Radius (ft)	Boom Length (ft)								Radius (ft)
	38.0	50.0	64.0/65.0	80.0	95.0	110.0/116.0	125.0	142.0	
8	150,000**								8
9	140,000								9
10	131,300	96,700	61,000						10
12	117,400	96,700	61,000	45,000					12
15	100,800	96,700	61,000	45,000	45,000				15
20	78,400	77,400	61,000	45,000	45,000	40,000			20
25	60,600	59,800	57,600	45,000	45,000	40,000	28,200		25
30	48,000	46,600	45,300	43,900	39,600	36,000	28,200	20,200	30
35		37,600	39,000	37,800	35,000	32,000	27,800	20,200	35
40		29,200	30,700	31,400	28,200	28,700	25,500	20,200	40
45			24,800	25,500	22,500	23,300	23,500	20,100	45
50			20,500	21,200	19,500	19,000	19,600	18,500	50
55			17,100	17,800	17,900	15,700	16,300	16,800	55
60				15,200	15,700	13,600*	14,500	14,300	60
65				13,100	13,500	12,600*	13,300	12,200	65
70				11,300	11,800	11,600*	11,500	10,400	70
75					10,300	10,600*	10,000	8,900	75
80					8,900	9,400*	8,700	7,700	80
85					7,800	8,200*	7,600	6,600	85
90						7,300*	6,600	5,600	90
95						6,400*	5,800	4,800	95
100						5,700*	5,100	4,100	100
105						5,000*	4,400	3,400	105
110							3,800	2,800	110
115							3,200	2,300	115
120								1,800	120
125								1,400	125

\*Boom Mode EM1, 116.0 ft  
\*\*Over Front Only

This information is not for crane operation. Operator must refer to the in-cab information for crane operation. Rated lifting capacities shown on fully extended outriggers do not exceed 85% of the tipping loads and on tires do not exceed 75% of the tipping loads.



PORTLAND OFFICE: 503.283.3111  
SEATTLE OFFICE: 206.784.1054  
[WWW.NESSCAMPBELL.COM](http://WWW.NESSCAMPBELL.COM)

14,500lb Counterweight On Tires – Stationary – Boom Centered Over The Front Between Tire Tracks (All Capacities Are Listed In Pounds)						
Radius (ft)	Boom Length (ft)					Radius (ft)
	38.0	50.0	64.0/65.0	65	75	
10	68,800					10
12	60,900	59,900				12
15	51,700	50,800	39,400			15
20	40,700	42,300	39,400	26,500		20
25	31,800	33,900	35,200	26,500		25
30	22,500	24,600	25,800	26,500	20,800	30
35		18,500	19,800	20,400	20,800	35
40		14,300	15,600	16,200	16,600	40
45			12,500	13,200	13,600	45
50			10,100	10,800	11,200	50
55			8,200	8,900	9,400	55
60				7,400	7,800	60
65				6,100	6,600	65
70				5,000	5,500	70
75					4,600	75
80					3,800	80
85					3,100	85

This information is not for crane operation. Operator must refer to the in-cab information for crane operation. Rated lifting capacities shown on fully extended outriggers do not exceed 85% of the tipping loads and on tires do not exceed 75% of the tipping loads.



PORTLAND OFFICE: 503.283.3111  
 SEATTLE OFFICE: 206.784.1054  
[WWW.NESSCAMPBELL.COM](http://WWW.NESSCAMPBELL.COM)



**14,500lb Counterweight On Tires – Boom Centered Over The Front Pick and Carry – Creep**  
(All Capacities Are Listed In Pounds)

Radius (ft)	Boom Length (ft)					Radius (ft)
	38.0	50.0	64.0/65.0	80.0	95.0	
10	67,600					10
12	59,200	58,300				12
15	49,300	48,500	36,400			15
20	37,700	39,200	36,400	26,500		20
25	29,700	31,300	32,300	26,500		25
30	22,500	24,600	25,800	26,500	20,800	30
35		18,500	19,800	20,400	20,800	35
40		14,300	15,600	16,200	16,600	40
45			12,500	13,200	13,600	45
50			10,100	10,800	11,200	50
55			8,200	8,900	9,400	55
60				7,400	7,800	60
65				6,100	6,600	65
70				5,000	5,500	70
75					4,600	75
80					3,800	80
85					3,100	85

**14,500lb Counterweight On Tires – Stationary – 360° Rotation**  
(All Capacities Are Listed In Pounds)

Radius (ft)	Boom Length (ft)					Radius (ft)
	38.0	50.0	64.0/65.0	80.0	95.0	
12	42,500					12
15	29,600	31,500				15
20	17,500	19,400				20
25	11,100	12,900	14,200			25
30	7,000	8,800	10,000	10,700		30
35		6,000	7,200	7,900	8,300	35
40		4,000	5,100	5,800	6,300	40
45			3,600	4,300	4,700	45
50			2,400	3,000	3,500	50
55				2,000	2,500	55
60				1,200	1,600	60
65					1,000	65

This information is not for crane operation. Operator must refer to the in-cab information for crane operation. Rated lifting capacities shown on fully extended outriggers do not exceed 85% of the tipping loads and on tires do not exceed 75% of the tipping loads.



PORTLAND OFFICE: 503.283.3111  
SEATTLE OFFICE: 206.784.1054  
[WWW.NESSCAMPBELL.COM](http://WWW.NESSCAMPBELL.COM)

## Fly Attachment Lift Capacity Charts – Optional

14,500lb Counterweight – Fully Extended Outriggers – 360° Rotation (All Capacities Are Listed In Pounds) Main Boom + 10 ft Manual Offset Fly (2°, 15°, 30° & 45° Offsets)									
Radius (ft)	Boom Length (ft)								Radius (ft)
	38.0	50.0	64.0/65.0	80.0	95.0	110.0/116.0	125.0	142.0	
10	41,500	42,700	44,300						10
12	36,000	36,600	42,600	44,100					12
15	35,100	35,900	36,400	44,100	44,000				15
20	34,100	34,800	35,500	35,900	36,000	30,800			20
25	33,500	34,000	34,700	35,200	35,500	30,800	22,800		25
30	33,500	33,600	34,200	34,500	34,800	30,800	22,800	16,200	30
35	33,500	33,500	33,800	34,300	33,500	30,000	22,800	16,200	35
40	30,100	30,700	31,300	28,500	28,400	27,500	22,100	16,200	40
45		24,800	25,300	25,700	22,600	23,200	20,400	16,200	45
50		20,600	21,000	21,300	18,400	18,900	18,900	16,200	50
55			17,700	18,000	16,100	15,800	16,100	15,200	55
60			15,100	15,400	14,900	13,200	13,600	13,900	60
65			13,000	13,200	13,400	11,500	12,200	11,800	65
70				11,500	11,700	10,600	11,200	10,100	70
75				10,000	10,200	9,800*	9,700	8,600	75
80				8,700	8,900	9,100*	8,400	7,300	80
85					7,800	7,900*	7,300	6,200	85
90					6,800	7,000*	6,300	5,300	90
95					6,000	6,100*	5,500	4,500	95
100						5,400*	4,700	3,700	100
105						4,700*	4,100	3,100	105
110						4,100*	3,500	2,500	110
115						3,600*	3,000	2,000	115
120							2,500	1,500	120
125							2,100	1,100	125

\*Boom Mode EM1, 116.0 ft

This information is not for crane operation. Operator must refer to the in-cab information for crane operation. Rated lifting capacities shown on fully extended outriggers do not exceed 85% of the tipping loads and on tires do not exceed 75% of the tipping loads.



PORTLAND OFFICE: 503.283.3111  
SEATTLE OFFICE: 206.784.1054  
[WWW.NESSCAMPBELL.COM](http://WWW.NESSCAMPBELL.COM)

<b>14,500lb Counterweight – Fully Extended Outriggers – 360° Rotation</b> (All Capacities Are Listed In Pounds)									
Radius (ft)	142 ft Main Boom Length								Radius (ft)
	35 ft Manual Offset Fly				58 ft Manual Offset Fly				
	2°	15°	30°	45°	2°	15°	30°	45°	
40	11,000								40
45	11,000				7,400				45
50	11,000	11,400			7,400				50
55	11,000	11,400			7,400				55
60	11,000	11,400	11,300		7,400				60
65	11,000	11,400	11,000	9,800	7,400	7,800			65
70	10,900	11,100	10,800	9,700	7,400	7,700			70
75	9,300	10,100	10,100	9,600	7,400	7,500			75
80	8,000	8,800	9,400	9,300	7,400	7,300	6,200		80
85	6,900	7,600	8,300	8,700	7,400	7,100	6,000	5,200	85
90	6,000	6,600	7,200	7,600	6,500	6,900	5,900	5,100	90
95	5,100	5,700	6,200	6,600	5,700	6,600	5,700	5,100	95
100	4,400	4,900	5,400	5,700	4,900	5,700	5,600	5,000	100
105	3,700	4,200	4,600	4,900	4,200	5,000	5,500	4,900	105
110	3,100	3,500	3,900	4,200	3,600	4,300	5,000	4,900	110
115	2,500	2,900	3,300	3,500	3,000	3,700	4,400	4,800	115
120	2,100	2,400	2,700	2,900	2,500	3,200	3,800	4,200	120
125	1,600	1,900	2,200	2,400	2,100	2,700	3,200	3,600	125
130	1,200	1,500	1,700	1,900	1,700	2,200	2,700	3,100	130
135		1,100	1,300	1,400	1,300	1,800	2,200	2,600	135
140			900	1,000	900	1,400	1,800	2,100	140
145						1,000	1,400	1,600	145
150							1,000	1,200	150

This information is not for crane operation. Operator must refer to the in-cab information for crane operation. Rated lifting capacities shown on fully extended outriggers do not exceed 85% of the tipping loads and on tires do not exceed 75% of the tipping loads.



PORTLAND OFFICE: 503.283.3111  
SEATTLE OFFICE: 206.784.1054  
[WWW.NESSCAMPBELL.COM](http://WWW.NESSCAMPBELL.COM)